

AUTO LENS EDGER

Operation Manual (v2.0)



REV.20190125

Preface

Dear respected user:

Thank you for choosing our product and trusting our company.

The patternless lens edger is developed specially for optical shops to edge the lens.

Please read the manual carefully and put it near the edger for easy reference.

Information of the manual doesn't have nature of the contract, thus can be modified without prior notice. The content has been checked strictly to make sure no errors. But it's impossible to avoid error or omissions so we are responsible for further update.

If user have not operated properly according to this manual and leads to edger problem, then we will not include the problem in the scope of our factory's warranty.









Attention:

Some machines with grooving and safe chamfering function;

DESCRIPTION OF SYMBOLS

Different symbols in manual can draw attention of users and can distinguish different matters.(e.g. matters related to safety)

Following diagram have lists all symbols and descriptions:

Symbol	Description
	Important warning, marking the meaning is: if the violation, inappropriate operation of the machine, and the risk of serious damage to the existence of life. Please read carefully.
	Import suggestion: may damage the machine or cause problem. Please read carefully.
	Necessary preparation Before any operation, make sure power is off.
	Electrical problem.
	Heavy product reminder The machine is heavy and requires more than two people to carry it.
	Rotate reminder: Don' t put hands near the rotating wheels.
	Pinching hands reminder: Please pay special attention when clamping lens.
	Must wear protective gloves Especially when cleaning and changing the water tank.
	Must ware work clothes, Especially when cleaning and changing the water tank.

CONTENT

Preface.....	- 1 -
1. ASSEMBLING.....	- 5 -
1.1 Open the packaging of machine.....	- 6 -
1.1.1 Warning.....	- 6 -
1.1.2 Procedure.....	- 6 -
1.2 remove the fixed transportation rails.....	- 7 -
1.2.1 Condition.....	- 7 -
1.2.2 Procedure.....	- 7 -
1.3 prepare the working table.....	- 8 -
1.3.1 Machine specification.....	- 8 -
1.3.2 Working table size and drilling hole rerquirement.....	- 9 -
1.4 Water supplying system.....	- 10 -
1.4.1 Description.....	- 10 -
1.4.2 Piper connectioin.....	- 10 -
1.5 Electrical connection.....	- 13 -
1.5.1 Electrical wire of the edger.....	- 13 -
1.6 Start the edger.....	- 14 -
2. SAFETY PRECAUTIONS.....	- 15 -
2.1 Notice.....	- 15 -
2.1.1 Operator.....	- 15 -
2.1.2 Machine.....	- 15 -
2.2 Suggestions.....	- 16 -
3. USE OF EDGER.....	- 17 -
3.1. Appearance.....	- 17 -
3.1.1 Appearance of the edger.....	- 17 -
3.2 INTRODUCTION OF OPERATE INTERFACE.....	- 18 -
3.2.1Display interface.....	- 18 -
3.2.2 Screen 1:1display.....	- 19 -
3.2.3 Optical scanner system.....	- 20 -
3.2.4 Change shape of pattern data.....	- 22 -
3.2.5 Pick up stored data.....	- 24 -
3.2.6 Fix center of lens, put the suction cup on lens.....	- 25 -
3.2.7 Edging lens interface.....	- 28 -
3.3 Lens processing.....	- 29 -
3.3.1 Clamp/remove the lenses.....	- 29 -
3.3.2 Start/stop the grinding procedure.....	- 30 -
3.3.3 Lens processing steps.....	- 30 -
3.3.4 Processing range.....	- 33 -
4. CONFIGURATION MENU.....	- 34 -
4.1 Configuration menu introduction.....	- 34 -
4.1.1 System menu interface.....	- 34 -
4.1.2 Calibrate size of scanner.....	- 35 -
4.1.3 Optical blocker calibration.....	- 35 -
4.1.4 The test menu.....	- 36 -
4.1.5 Setting menu.....	- 38 -
4.1.6 Initial parameter setting.....	- 39 -
4.1.7 Processing statistics table.....	- 39 -
5. DAILY MAINTENANCE OF MACHINERY.....	- 40 -
5.1 Maintenance instructions.....	- 40 -
5.2 Maintenance of touch screen parts.....	- 40 -
5.3 Replace removable clamps.....	- 41 -
5.3.1 Replace the right clamp rubber pad.....	- 41 -

5.4 REPLACE LENS FEELER	- 42 -
5.5 Clean/replace water-proof cover.....	- 43 -
5.6 Clean the filter and water tank.....	- 44 -
6. TECHNICAL SPECIFICATIONS	- 45 -
6.1 Features	- 45 -
6.2 Technical parameters.....	- 46 -
7. ATTACHMENT LIST (PACKING PARTS)	- 47 -

1. ASSEMBLING

#1



#2, #5



 Please keep packaging materials

#3



#4



#6



1.1 OPEN THE PACKAGING OF MACHINE

1.1.1 WARNING



> Machine must be put the same direction as mark shown on package, cannot be put upside down.

> Put the machine on flat and stable surface.

1.1.2 PROCEDURE

OPEN THE PACKAGE AS FOLLOWING PROCEDURE:

#1 At least 2 person carry edger onto the ground,

#2 Cut off the 4 packing belt outside the package,

#3 Remove the package,

#4 Check supplied parts on attached list (tool box, piper etc.),

#5 Take out protecting plastic form inside the machine,

#6 Remove 4 fixing screws at the machines transportation rails,

#7 At least 2 persons carry machine from rail to working table,

#8 Remove carriage fixing device,

#9 Keep the machine package, we suggest you keep packages flat for storage



Remove carriage fixing device

1.2 REMOVE THE FIXED TRANSPORTATION RAILS

1.2.1 CONDITION

- > Put the machine on the working table,
- > Around the machine, we need enough space.

1.2.2 PROCEDURE

Remove the rails in following procedures:

#1 Under the help of another person, turn over the machine, so you can find the 4 screws that used to fix the rails

#2 Use 13mm inner hexagon spanner to take off the screws, remove the rails

#3 Keep the rails together with the other packing materials

As shown in below figure:

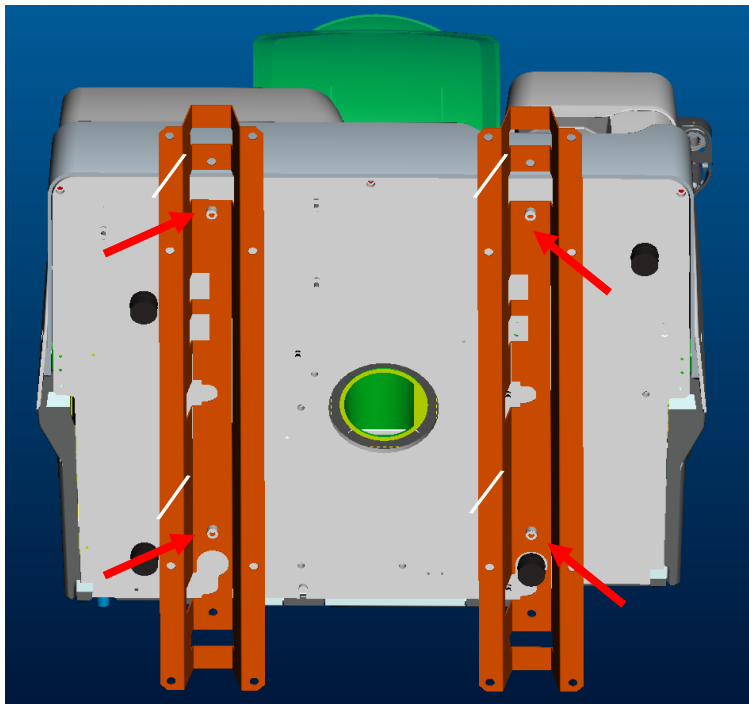

1.3 PREPARE THE WORKING TABLE

1.3.1 MACHINE SPECIFICATION

Machine size as below figure:

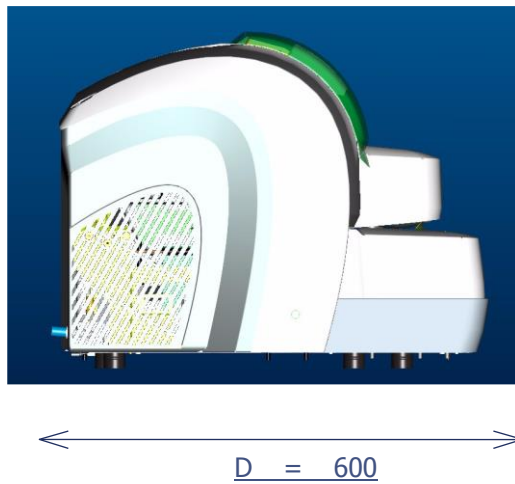
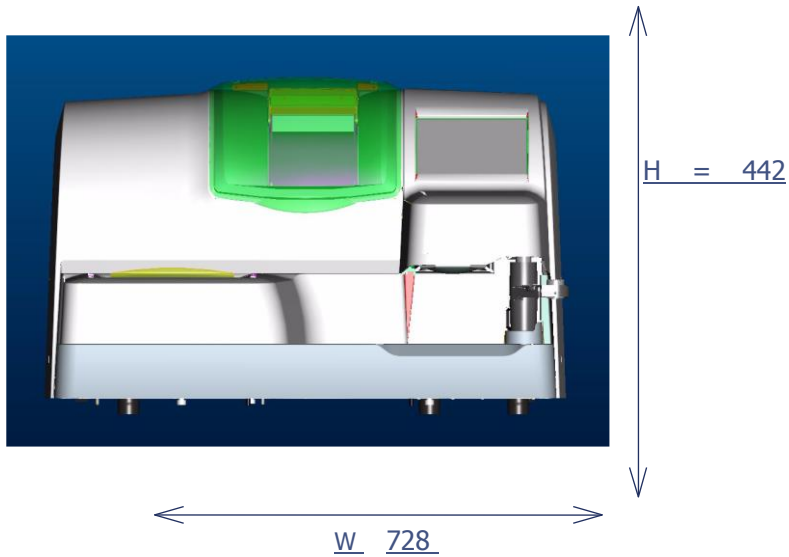

- > length = 728mm
- > height = 442mm
- > width = 600mm
- > total weight = 75kg

1.3.2 WORKING TABLE SIZE AND DRILLING HOLE RERQUIREMENT

As following figure, it shows the machine size at the table and also the drain piper hole position. Before drilling hole, make sure the position of machine.

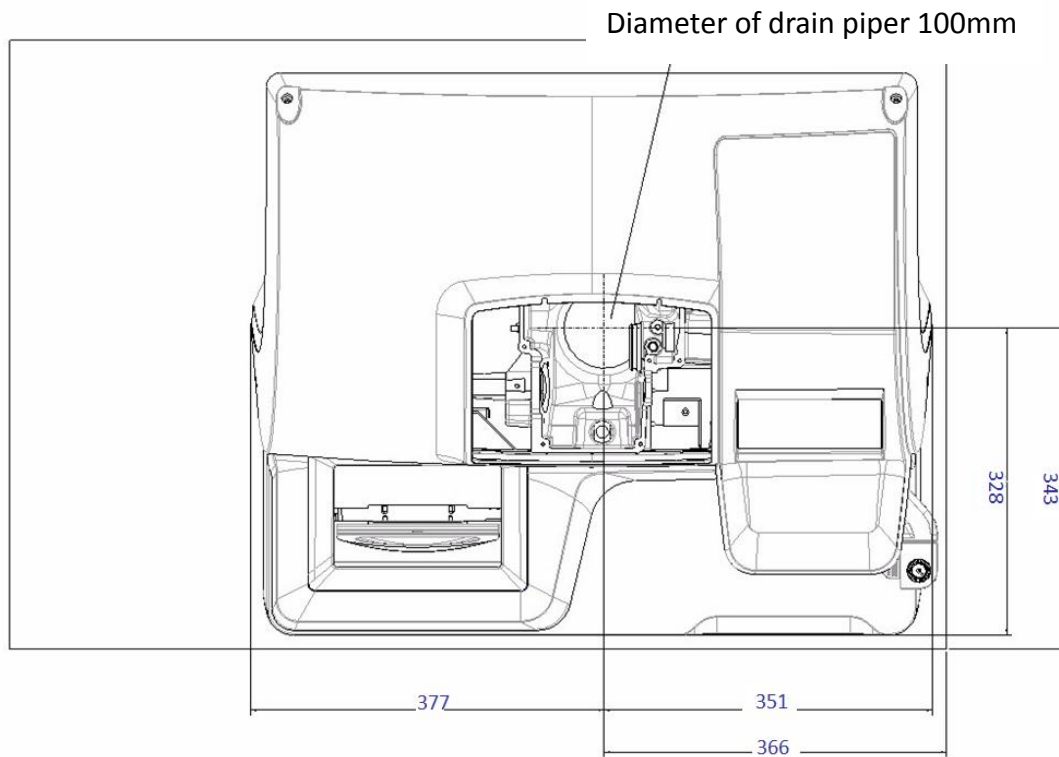

NOTE:

> Following size for reference:

>>Length of machine: 728mm;

>>Width of machine: 600mm;

>>Diameter of drain piper: 100mm;

>>Distance of center of drain hole to right side of machine: 351mm;

>>Distance of center of drain hole to front side of machine: 328mm;

- > Leave enough space around the edger.
- > Make sure the working table to be flat and stable.
- > Keep machine away from the heat source.

1.4 WATER SUPPLYING SYSTEM

1.4.1 DESCRIPTION

1.4.1.1 General status:

- > Edger must install valve to control water supply, position of valve cannot be 80cm higher than edger. Valve must be operated easily so when stop machine, people can close water supply anytime.
- > Drain piper diameter is 100 mm. To make sure discharging all scrap, we should have at least a 5% slope.

1.4.1.2 Filter tank with water pump

- > Length=500mm width=400mm height=280 mm
- > Volume: 50L

1.4.1.3 Water pump

- > Power = 40 W
- > Flow rate = 12L/Minute
- > Discharge height = 3.0m
- > Voltage = 220V-230V/50Hz 110V-115V/60Hz



1.4.1.4 Magnetic valve

- > Voltage = 220V-230V /50Hz 110V-115V /60Hz
- > Power = 20 W



1.4.2 PIPER CONNECTIOIN

- > Piper connection as below figure:

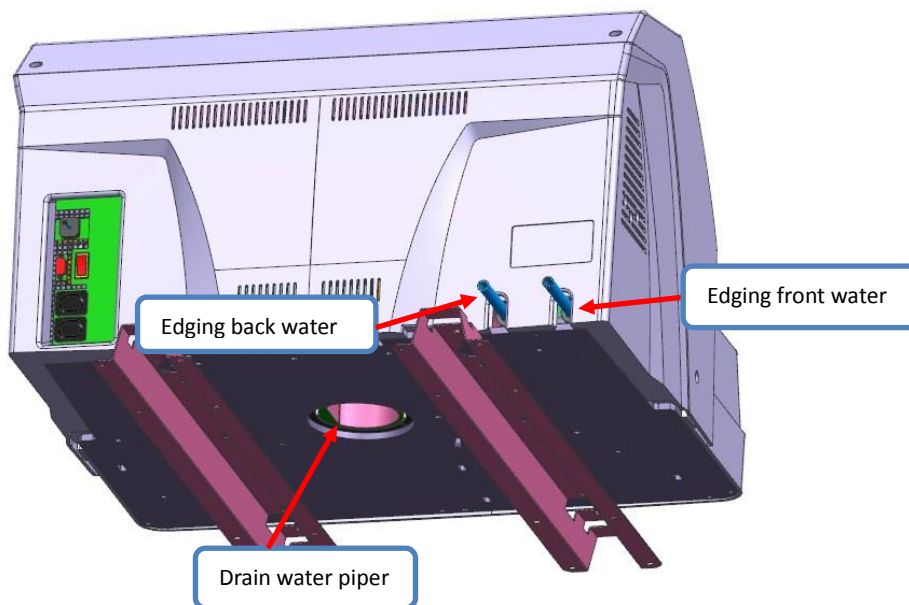

1.4.2.2 Procedure

As below figure

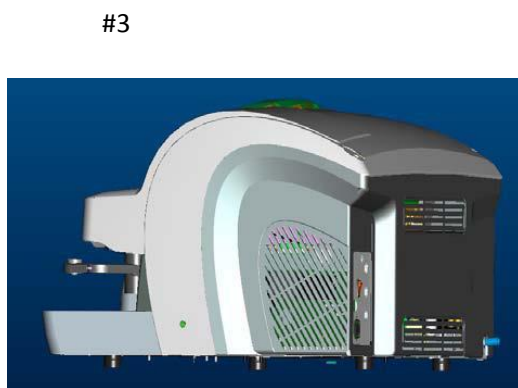

Connecting pump or magnetic valve power



Connecting pump to use circulating water

Connecting magnetic valve to supply water directly

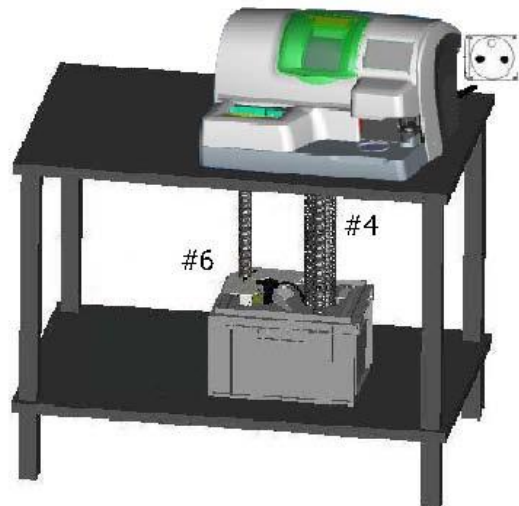
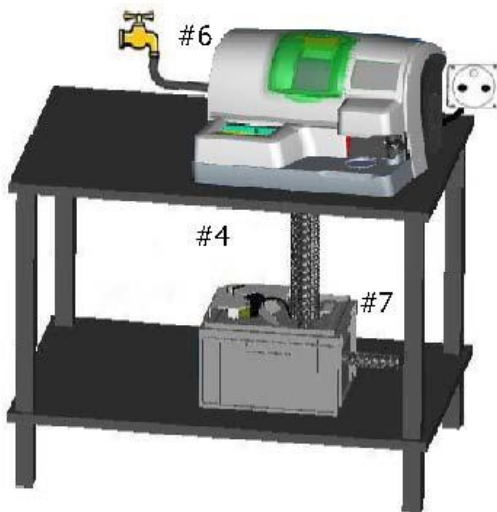

Follow below steps to connect water supply piper to edger, and fix.

#1 Checking if power of machine is off, power should be cut.

#2 Checking if water supply is closed.

#3 Make sure machine is Place horizontally => regulate 4 screws under the machine

#4 Connect the drain piper to the bottom of machine

#5 Connect the water supply pump to running water or pump

#6 If choosing running water, then need to connect to drain piper

#7 If the water supply is clogged, check the permeability of the pipe, especially around the magnetic valve.

#8 Connect the pump or magnetic valve to power.

1.5 ELECTRICAL CONNECTION

1.5.1 ELECTRICAL WIRE OF THE EDGER

>Power plug must be grounded. When assembling, outer cover must be grounded.

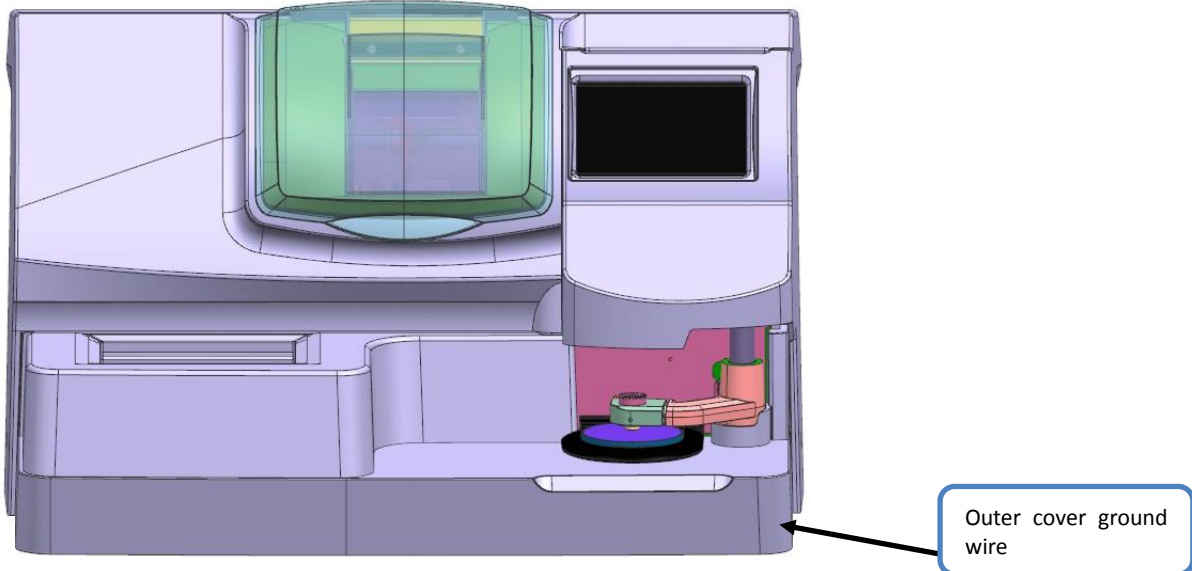

#1 Checking if power of machine is off, power should be cut.

#2 Connect scanner to RS232 port

#3 Please plug in power and plug of water pump or magnetic valve.

When connecting edger with its supporting equipment, please follow below figure:

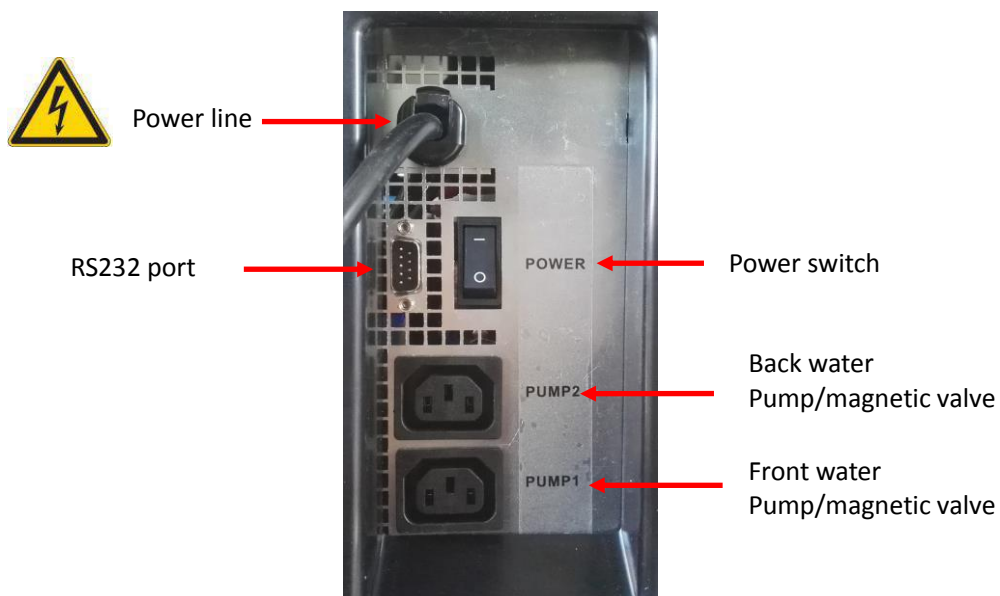

1.6 START THE EDGER

Follow below procedure to start the edger:

#1 Checking if power of machine is off, power should be off.

#2 Assemble the chuck and chuck seat to main axis

#3 Plug in, turn on the switch (ON/OFF switch)

#4 Simulate start, adjust left side flow regulating screw to regulate nozzle's flow and water quantity at edging area

#5 Obtain 1 to 2 tasks to test if machine is running regularly

Water quantity regulating at edging area, like below figure:

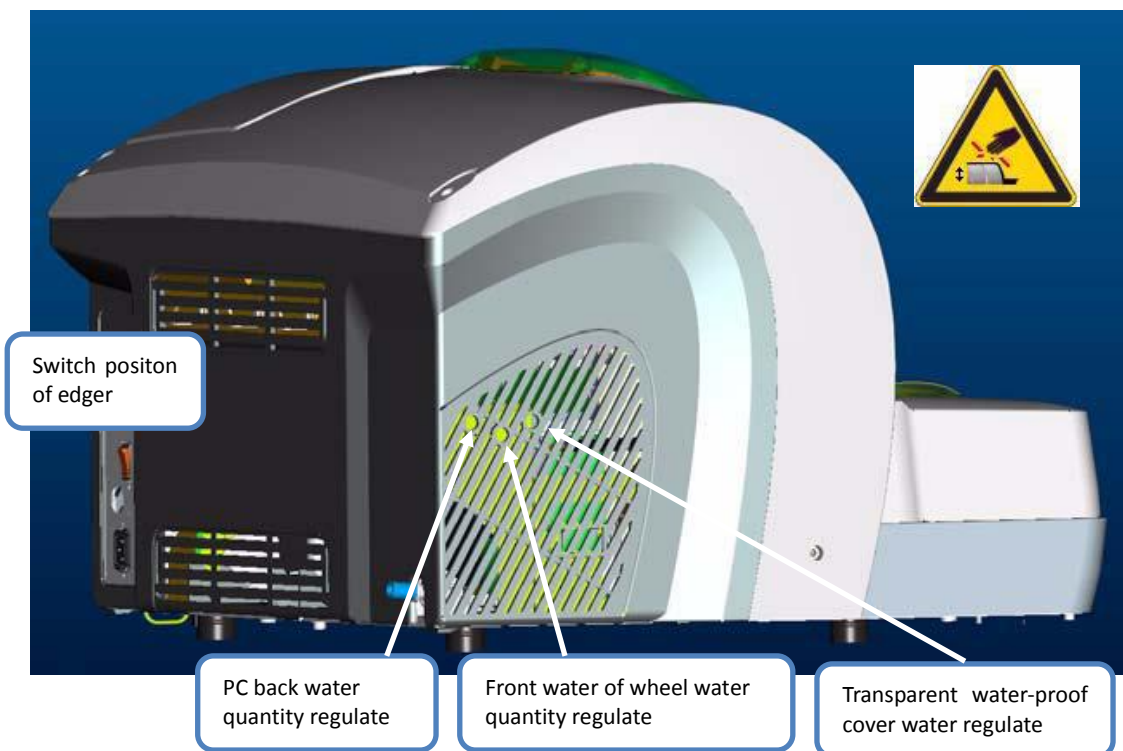

2. SAFETY PRECAUTIONS

2.1 NOTICE

2.1.1 OPERATOR

- > Please read the manual carefully and put it near the edger for easy reference.
- > The machine has rotating device, the wheel have potential risk, Don't put hands near the rotating wheels.
- > Machine is heavy and need to be carried by at least 2 persons.
- > When start clamping, put your hands outside of contacting area.
- > Before touching the fuse, the power cord must be disconnected.
- > During the installation, you must ensure that the water circuit is well sealed.
- > The power plug must be unplugged before repair the edger.

2.1.2 MACHINE

- > The voltage of the power supply must be in accordance with the rated voltage marked on the label on the back of the machine. Contact the professional electricians if the voltage of the installation site is uncertain.
- > Switch located behind the machine, marked ON / OFF. Plug used to disconnect the main power.
- > When lightning or prolonged un-use, please cut off the connection with the main power supply.
- > The machine should be away from the heat sink and other heat sources which affect the operation performance of the equipment.
- > Do not obstruct and cover the vents on the carriage to ensure proper operation of the machine.
- > The machine must be installed in a well-ventilated room.
- > Do not overload the socket or plug or this could cause a fire or electric shock.
- > Avoid using drawn leads as power cables.
- > Machine should stay away from wind and sand environment.
- > Any maintenance job (need to open, close the cover) must obtain the consent of the manufacturer or its distributor.

- > Sign at different place  Tips may cause the corresponding damage, should pay special attention to.
- > Controlling pump socket => electric shock hazard.
- > Edging area=> physical damage.
- > Water supply system => Water pressure in excess of 1 bar is dangerous.

2.2 SUGGESTIONS

- > Observe the equipment maintenance requirements.
- > Place the power cord properly.
- > All maintenance matters, please contact with the seller and professional technical personnel, must use the appropriate accessories.
- > Only online with the device specified by the vendor.
- > If strictly implement the instructions in the manual, you can ensure the normal operation of its various functions.
- > The equipment must be cleaned regularly.
- > Wipe the cover with a soft, damp cloth dampened with a little alcohol .
- > Note: You can not use the following items when cleaning:
 - Liquid containing ammonia, soda or acetic acid,
 - Organic solvents containing acetone, benzene or chlorylene.

- > Touch screen:
 - >> Do not force the touch screen, otherwise it will be fractured.
 - >> Can not use pen, scissors, pliers and other sharp objects pressure touch screen.
 - >> When operating the touch screen, your hands must be kept dry.
 - >> Clean the touch screen with a soft, clean, dry cloth.

- > Edging system:
 - >> Before starting the edger, check if the water system is ready (valve on).
 - >> The water system must ensure to be sealed well.
 - >>If you use recycled water, the water inside the tank must be replaced regularly.
 - >>Periodically check the probe, if there is wear or damage, it should be promptly replaced.
 - >> Clean the surface of CR39 daily with water and a soft sponge or a brush to avoid scratching the plastic surface.
 - >> Regularly wash the water-proof cover.

If user have not operated properly according to this manual and leads to edger problem, then manufacturer wont be responsible for any problem.



3. USE OF EDGER

3.1. APPEARANCE

3.1.1 APPEARANCE OF THE EDGER

Below figure is panorama of edger

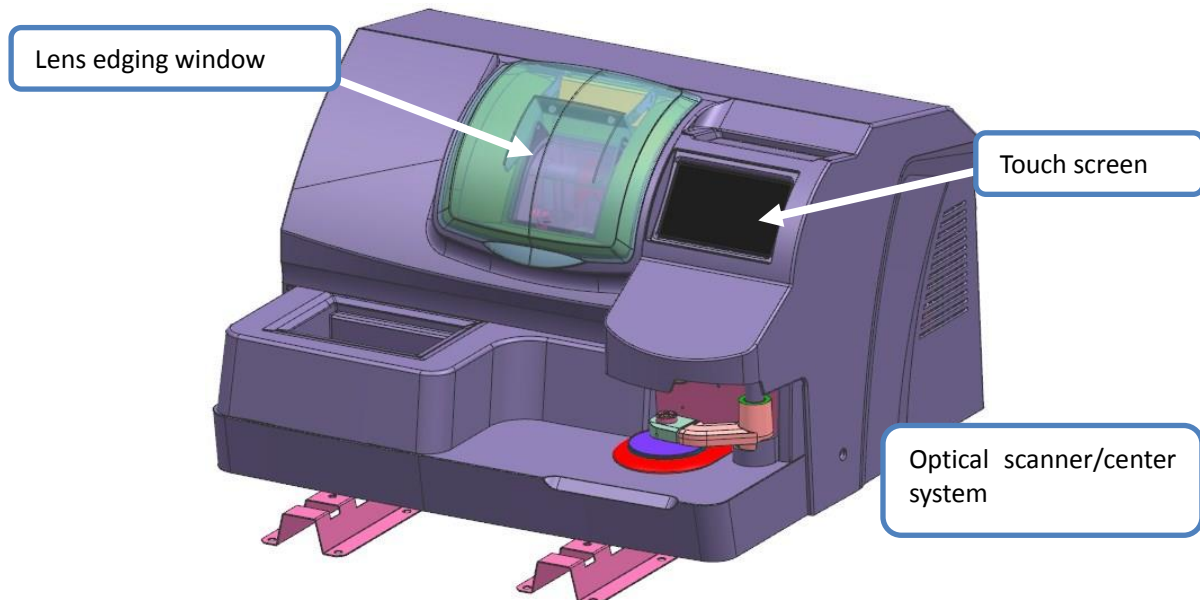

3.1.1.1 Touch Screen

> Function of touch screen:

- >> Operate interface, input edging task data
- >> Showing lens frame and lens shape, input edging data

3.1.1.2 Optical scanner/center system

> Function of optical scanner:

- >> Automatic recognize lens pattern, confirm the pattern size data

> Function of center system

- >> Manually fix the center for dotted normal lens, bi-focal and progressive lens.

3.1.1.3 Lens edging window

> Function of the edger:

- >> Edging the lens according to data of lens material, shape, degree etc.

3.2 INTRODUCTION OF OPERATE INTERFACE

3.2.1 DISPLAY INTERFACE

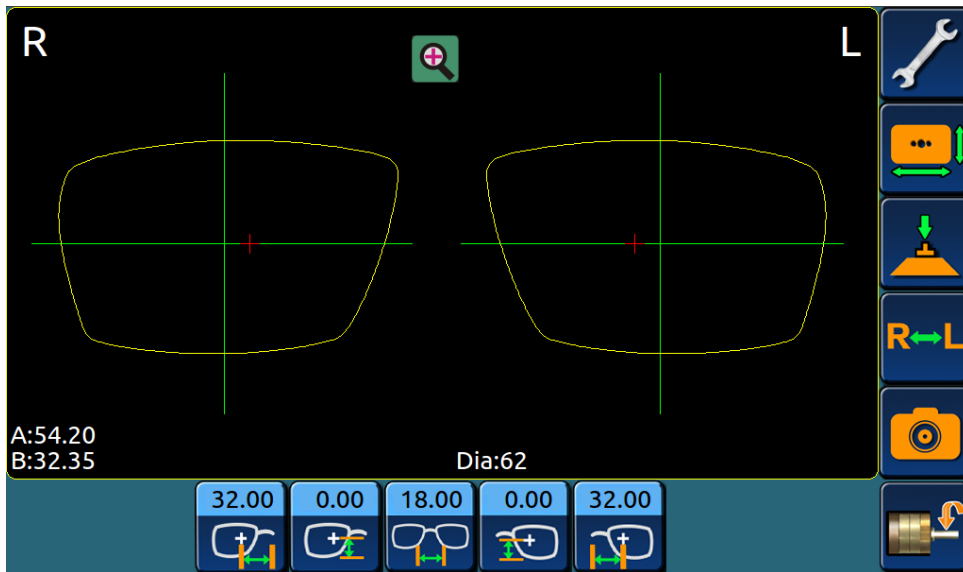

>>Menu interface;



>>Enter data change interface, can change shape of lens;



>>Enter optical center system, decide center of lens;



>>Mirror display of left and right eye data;



>>Enter optical scanner system, scan size of lens pattern;



>>Enter lens edging interface;



>>Obtain and display data of lens which is to be edged;



>>Input right eye PD;



>>Input left eye PD;



>>Input right eye PH;



>>Input left eye PH;



>>Input DBL;



>>Enter 1:1 display interface:

Dia >>Minimum Diameter of raw lens required to edging present lens;

3.2.2 SCREEN 1:1DISPLAY



>Click on screen, enter lens frame 1:1 display screen.

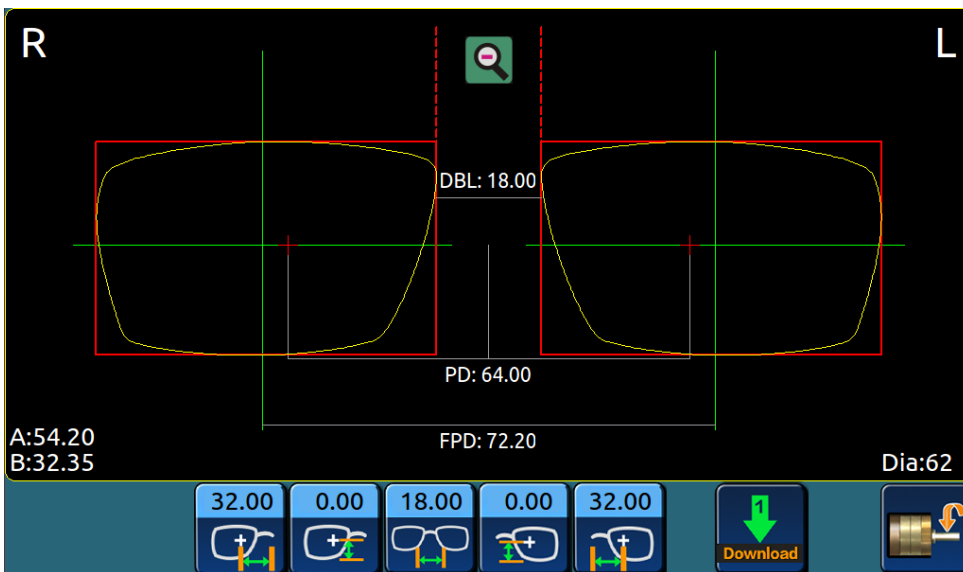

>Click, go back to main menu.

>>DBL: Nasal distance of lens frame;

>>PD: Pupil distance of eyes;

>>FPD: Geometry center distance of lens frame;

>>Dia: Minimum Diameter of raw lens required to edging present lens;

>>A: Maximum width of lens pattern;

>>B: Maximum height of lens pattern;

3.2.3 OPTICAL SCANNER SYSTEM



>Click icon, enter optical scanner system.

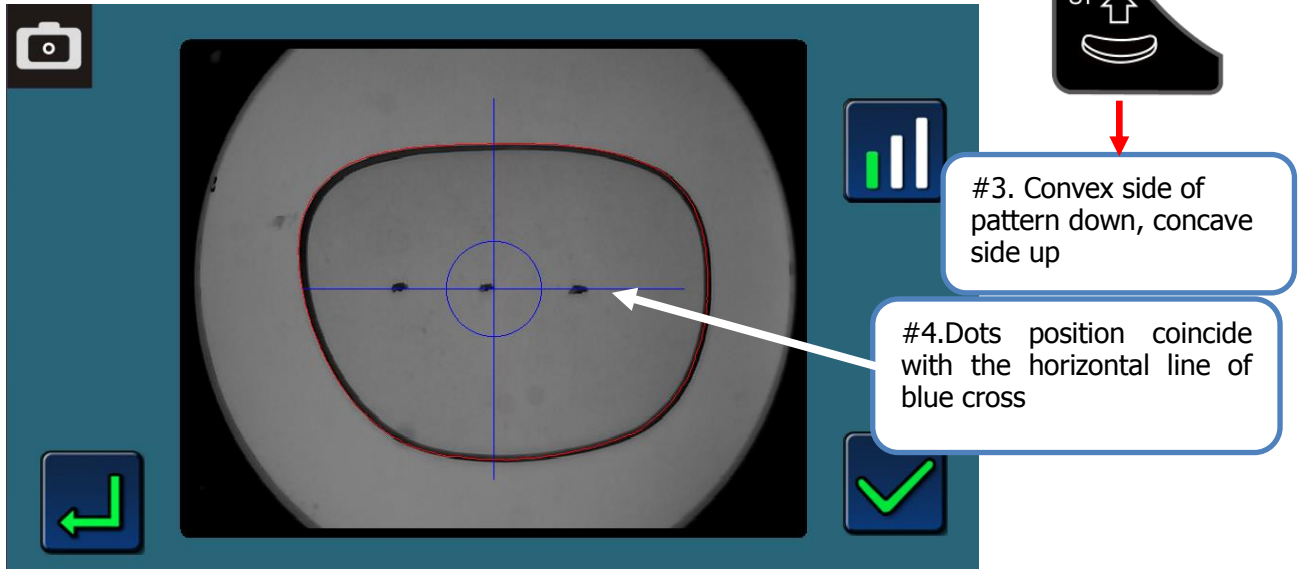

>>CCD brightness control



>>scanned data confirm



>>return back

Operation of lens pattern scan:

#1 Using lens meter to dot on lens pattern

#2 Clean the object stage, cannot have any dust or dirt when scanning

#3 Convex side of pattern down, concave side up

#4 Dots position coincide with the horizontal line of blue cross

#5 System will recognize lens frame data and show in red line

#6 After confirm scanned data, input DBL of lens frame

#7 Input PD data

#8 Input PH data

R 18.00 10.00< <30.00 L

#6 DBL of lens frame

A:54.20
B:32.35

32.00 0.00 18.00 0.00 32.00

R 32.00 20.00< <40.00 L

#7 Input PD data

A:54.20
B:32.35

32.00 0.00 18.00 0.00 32.00

R 0.00 -10< <10 L

#8 Input PH data

A:54.20
B:32.35

32.00 0.00 18.00 0.00 32.00

3.2.4 CHANGE SHAPE OF PATTERN DATA



>Click  icon, enter pattern data change shape interface,

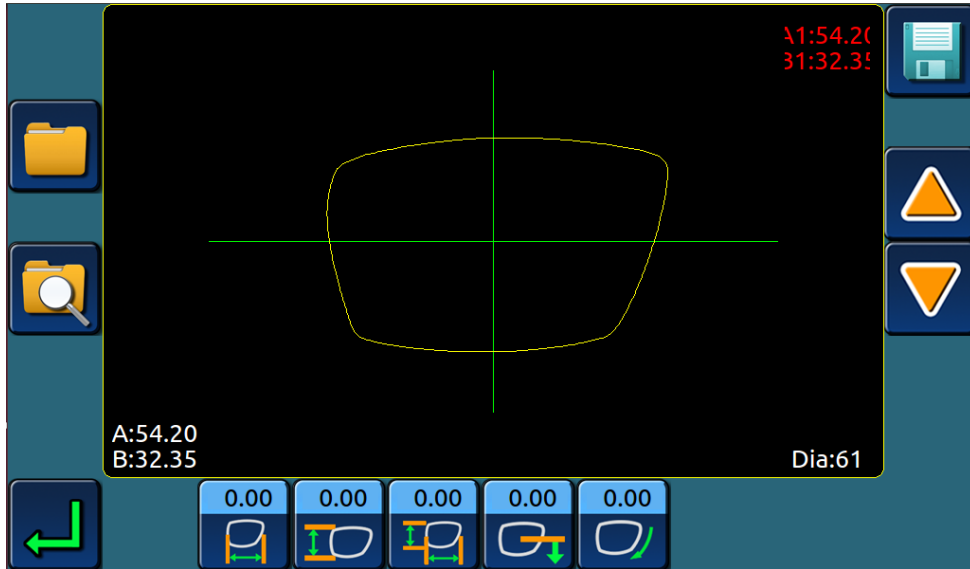

>>Obtain existing pattern data from internal storage;



>>Search for pattern data from internal storage;



>>Save present pattern data into internal storage;



>>Height of pattern don't change, width change;



>>Width of pattern don't change, height change;



>>Width and height of pattern change;



>>Shape of pattern bottom side change;



>>Pattern data rotate;



>>Pattern data angle rotate;



>>Return back.

3.2.4.1 Save pattern data



>Click  icon, the system will pop up a save window, input pattern number, like below figure.

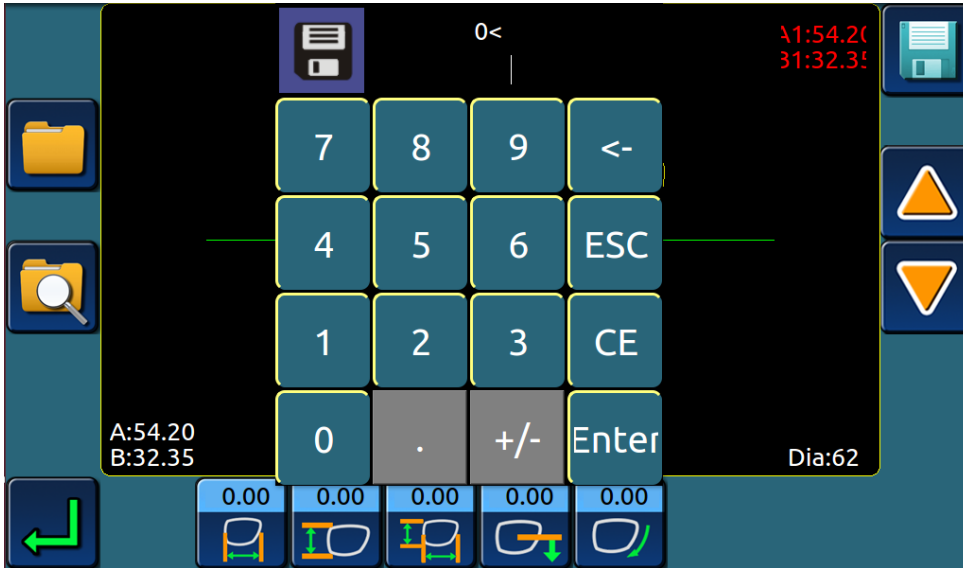

>Click "enter" button, system will save present pattern data automatically.

3.2.4.2 Search for pattern data



>Click  icon, the system will pop up the search window, like below figure.









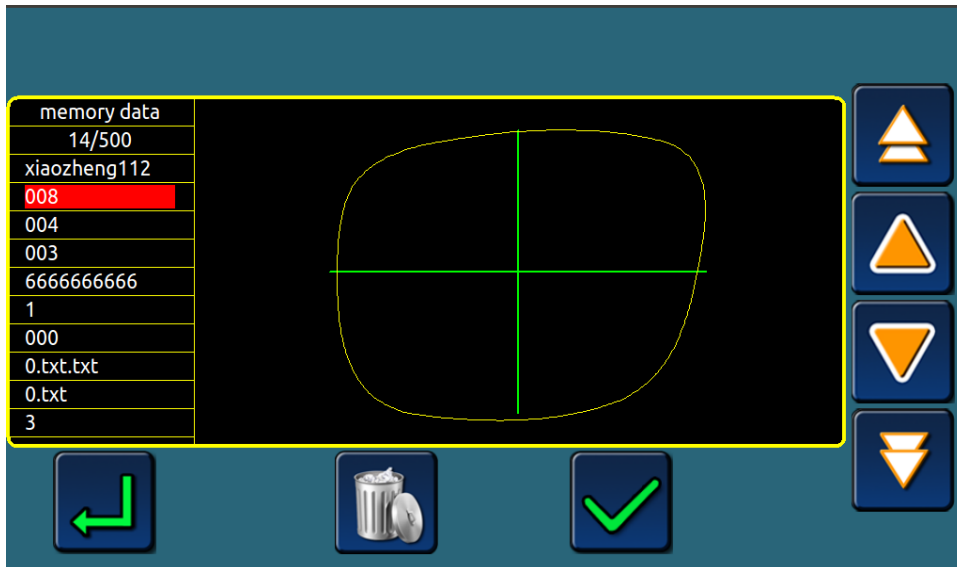

>Input the number of pattern you want to search, press "enter" icon, system will search for pattern data automatically.

3.2.5 PICK UP STORED DATA



>Click  on the shape change interface, enter the template data retrieval interface, the memory data list will be showed



-  >>Display previous page data;
-  >>Display next page data;
-  >>Display the previous data;
-  >>Display the next data;
-  >>Retrieve the current data;
-  >>Delete memory data;
-  >>Return.





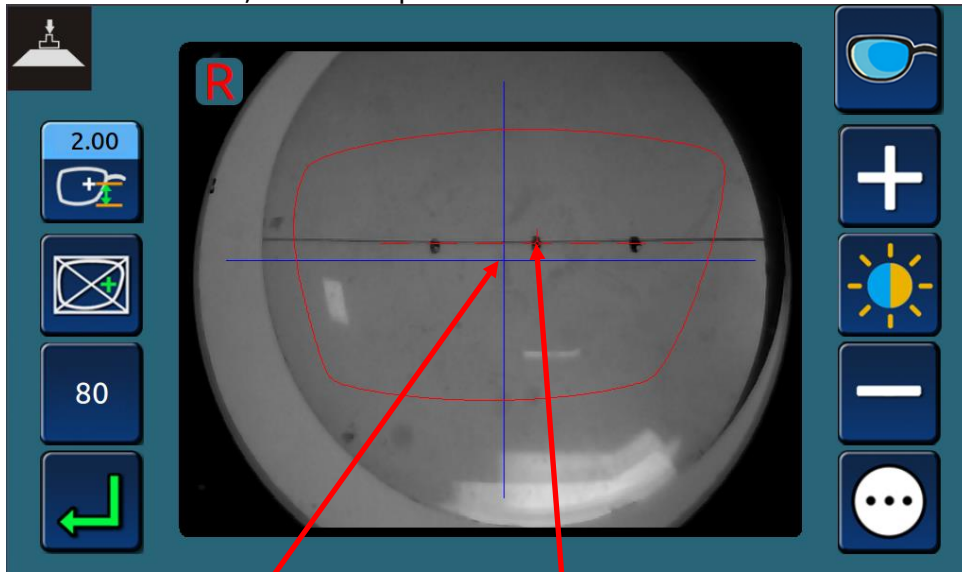





3.2.6 FIX CENTER OF LENS, PUT THE SUCTION CUP ON LENS

>Press  icon, enter the optical center interface.



Optical center mode

Geometry center mode

-  >>right eye
-  >>left eye
-  >>CCD increase brilliance
-  >>CCD decrease brilliance
-  >>normal mode
-  >>bifocus mode
-  >>progressive mode
-  >>PD setting
-  >>geometry center mode
-  >>optical center mode
-  >>initial diameter of lens

>Single focus lens fix center

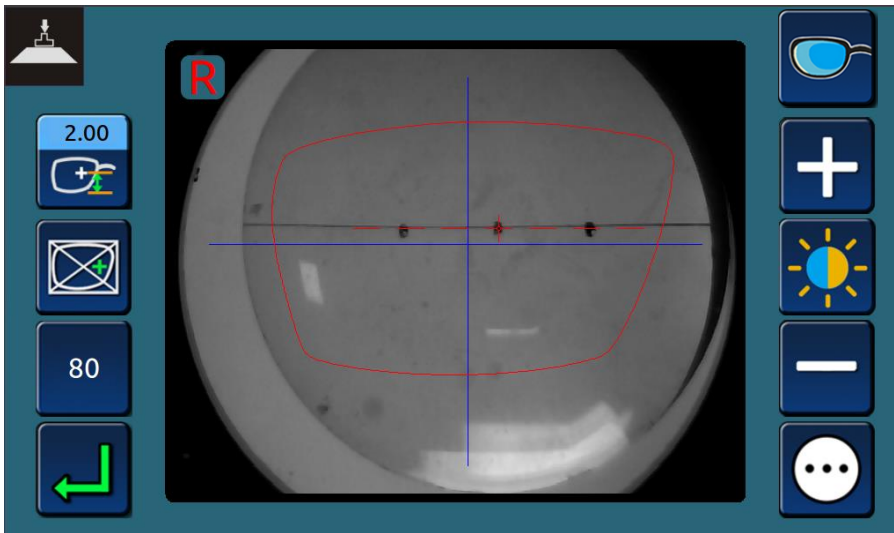

>Bifocus lens fix center

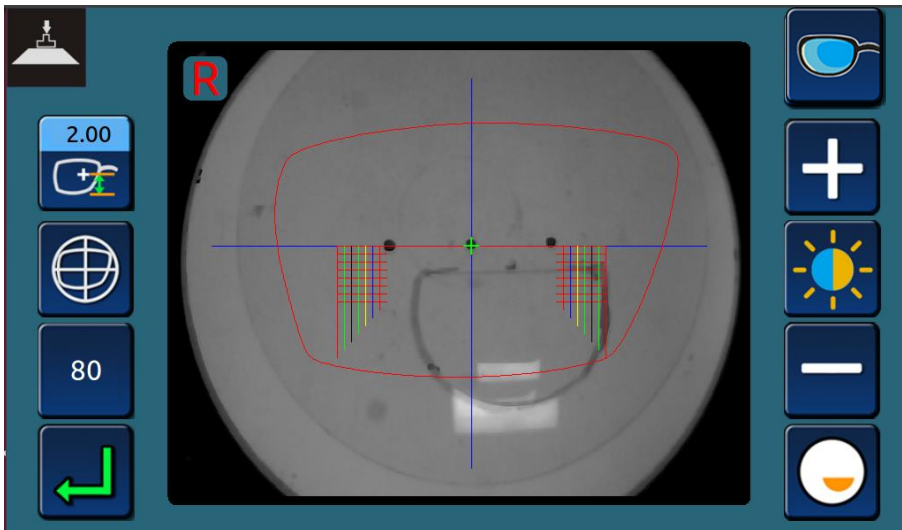

>Progressive lens fix center

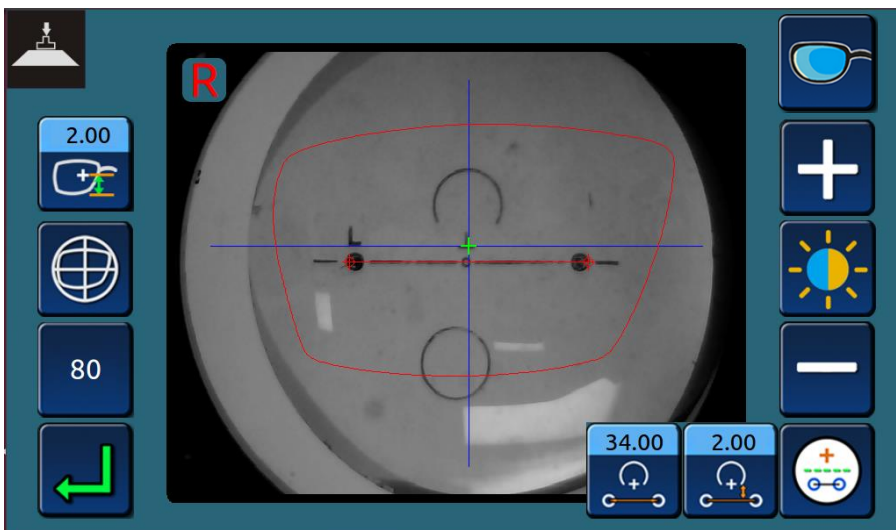

> Insert suction cup, overturn the seat

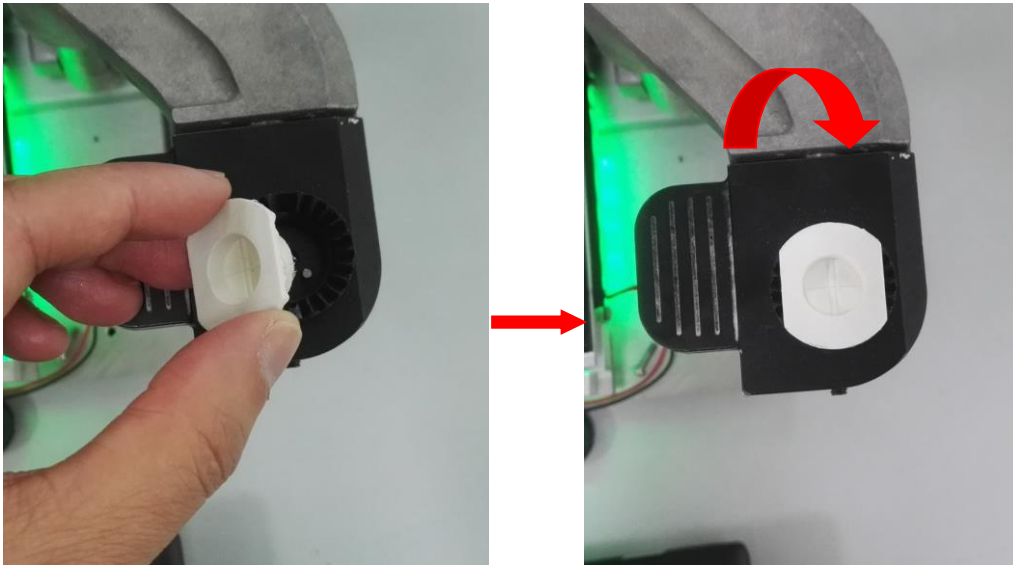

> Choosing geometry or optical center mode, rotate the arm, press the suction cup.

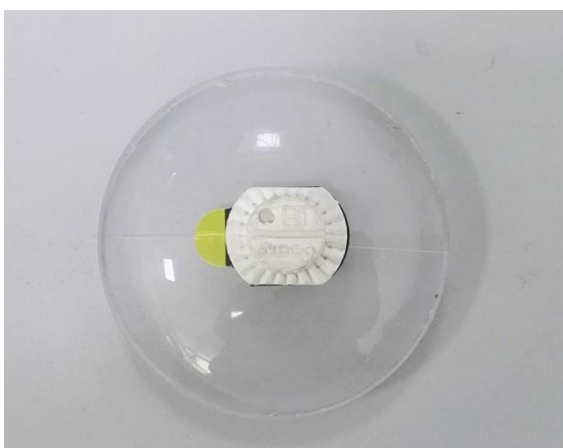
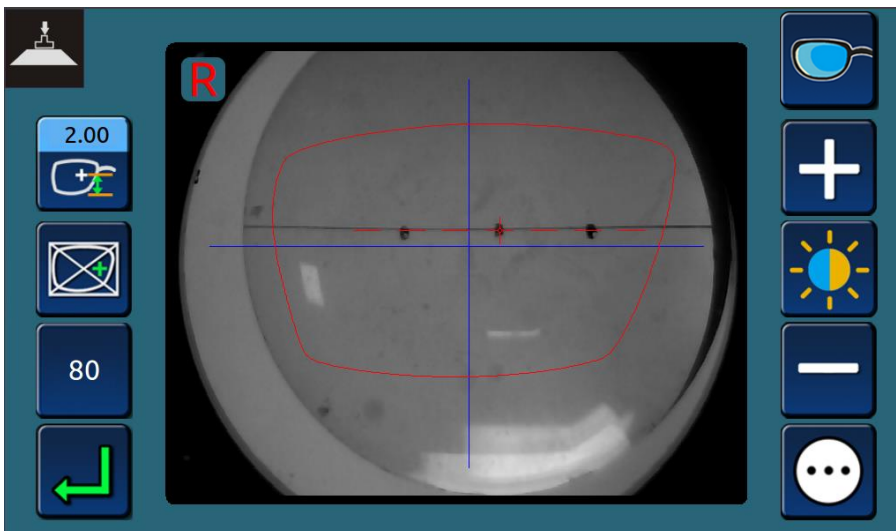

3.2.7 EDGING LENS INTERFACE



>Press icon, enter the edging lens setting interface.

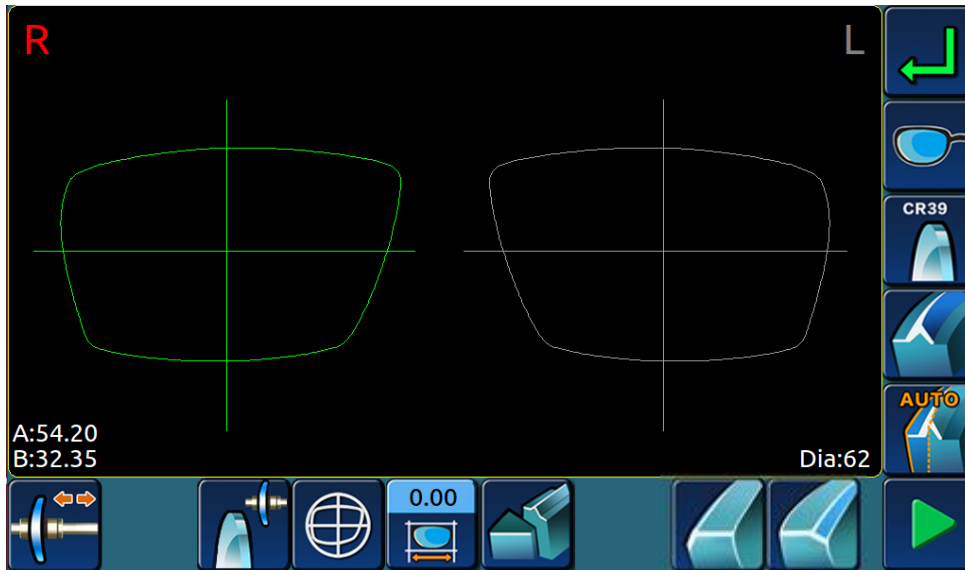

1. Left and right eye processing options:

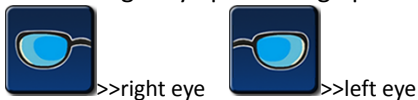

2. lens material options:



3. edge shape options:



4. Sharp edge rate:



5. Grooving rate **(only apply to edger with grooving function;)**:



6. Front side safe chamfering **(only apply to edger with safe chamfering function):**



7. Backside safe chamfering **(only apply to edger with safe chamfering function):**





>> backside safe chamfering(middle)



>> backside safe chamfering(large)

8. Lens processing mode:



>>Optical Center mode



>>Geometric center mode

9. Polishing choice:



>>polish



>>not polish

10. Others:



>>unlock the lens



>>start to proceeding



>>stop proceeding



>>proceeding size



>> retouch

11. Clamping pressure:



>>(level one)Fragile lens



>>(level two)normal lens



>>(level three)slippery lens



>>return

3.3 LENS PROCESSING

3.3.1 CLAMP/REMOVE THE LENSES

> Clamp the lens into grinding window

After all the grinding data is entered, clamp the lens;

Each kind of lens should choose appropriate clamp

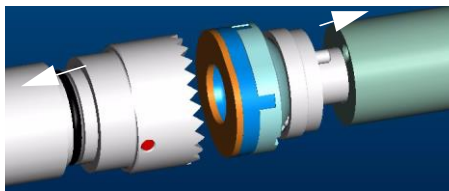

19mm small clamp

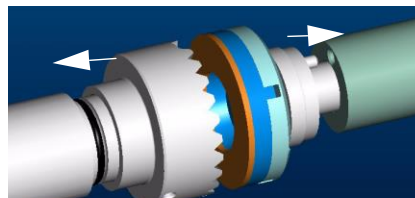

25mm big clamp

The warning information will display if the processed lenses needs special clamp,as the following figure:

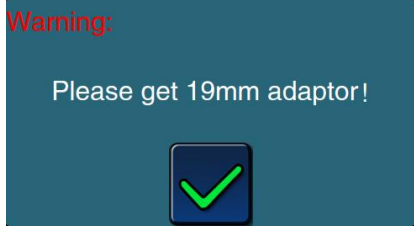

Warning: please install 19mm small clamp

> REMOVE THE LENS FROM THE GRINDING WINDOW

Open the water-proof cover after the machine stops or breaks.



Press icon, clamp will open automatically.

Taking out lens, don't take off the suction cup, in case of modifying.

3.3.2 START/STOP THE GRINDING PROCEDURE

> STAT EDGING PROCEDURE:

After enter all data of grinding and put lens into clamp,



press icon

> STOP EDGING PROCEDURE



If you want to stop the procedure, press icon. When the grinding is processing, this key can be transferred from another key.

3.3.3 LENS PROCESSING STEPS

> Full frame lens processing

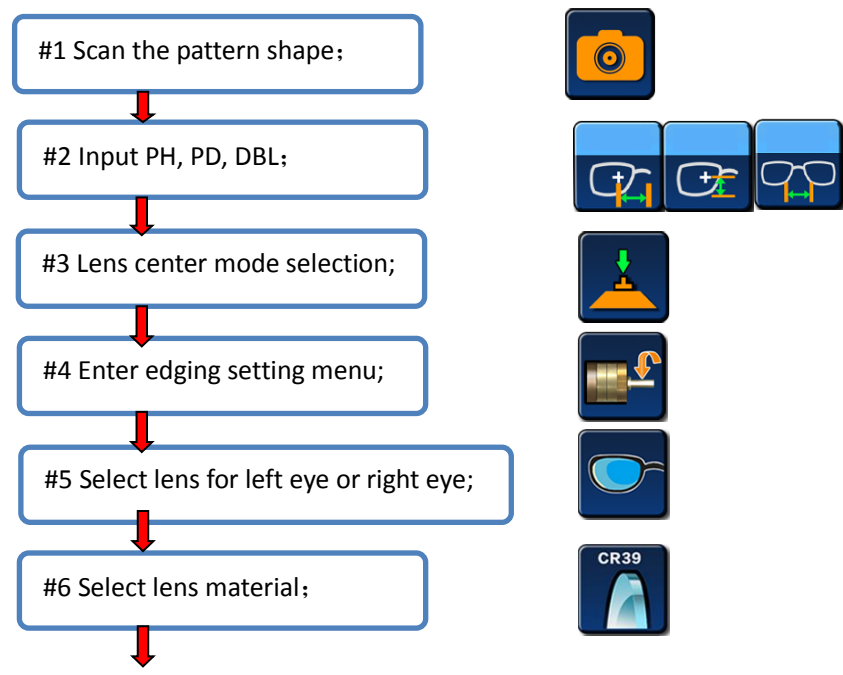

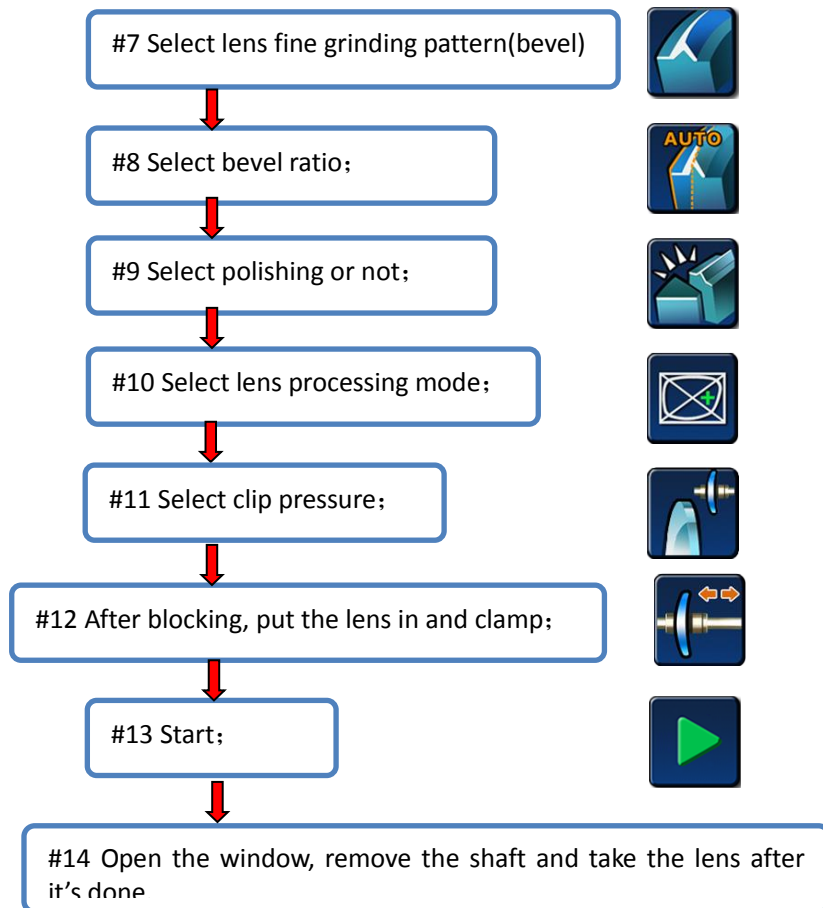

> Automatic bevel

The tip vertex position is automatically located 1/3 of the front of the lens.

> 33% bevel

The apex of the tip is located about 33 percent above the front of the lens.

> 50% bevel

The apex of the tip is located at 50% of the front surface of the lens.

> Front bevel

The tip vertex position is located on the front surface.

> Back bevel

The apex of the tip is located on the back surface.

IMPORTANT NOTE:

> If the maximum thickness of the lens is less than 2mm, the position of the bevel/slot will be automatically located at half of the lens.

> **Half - frame or rimless lens processing**

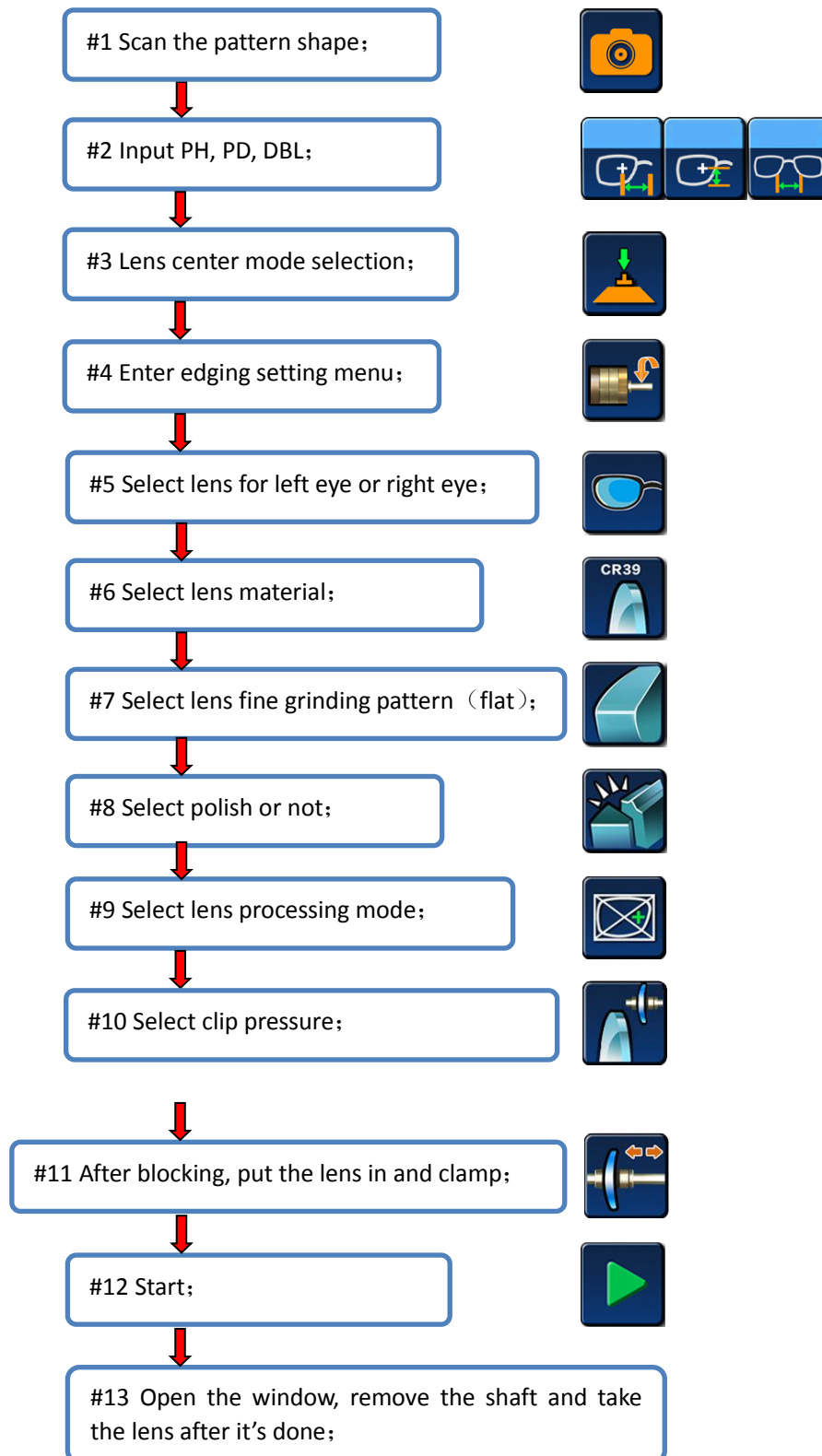

3.3.4 PROCESSING RANGE

> Lens

Diameter: Unprocessed lenses, with a diameter of 80mm and 10mm offset, that is to say, the maximum diameter of 100mm without offset lenses.

Thickness:

maximum thickness of resin lens: 18mm

maximum thickness of glass lenses: 16mm

Lens minimum center thickness: 1.2mm

Completed rough lens, the maximum thickness of the flat side: 11mm

Completed rough lens, the maximum thickness of the edge of the glass: 15mm

Completed rough lens, the maximum thickness of the resin tip: 15mm

> Shape

The minimum height of the flat: 19.00mm

The minimum height of bevel: 19.00mm

> Machining range diagram

>> Flat lens

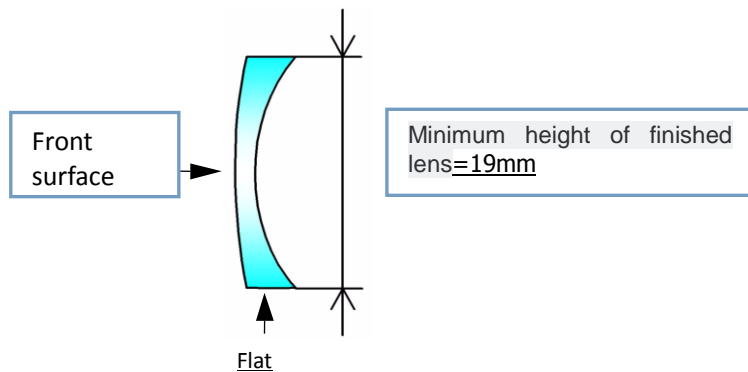

>>Bevel lens

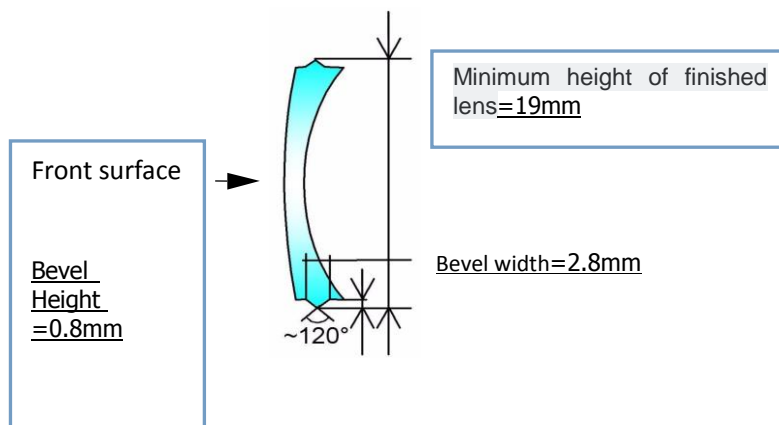

4. CONFIGURATION MENU

4.1 CONFIGURATION MENU INTRODUCTION

4.1.1 SYSTEM MENU INTERFACE



> Click the icon  on the main interface, Enter menu password, Enter the menu.



>> Calibrate size of scanner;



>> Calibrate of optical blocker;



>> Offset the scanning size;



>> Memory data export;



>> Memory data import;



>> The whole machine test;



>> The machine set;



>> Initial settings;



>> Processing statistics table;

4.1.2 CALIBRATE SIZE OF SCANNER



>Press icon , enter scanner size calibration interface.

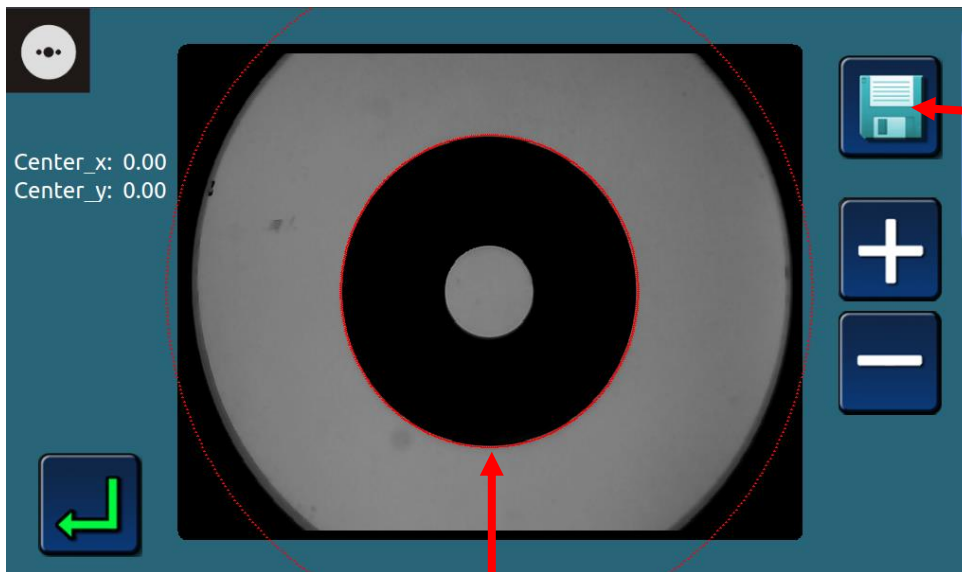

#2 Red circle coincide with the calibration plate, press "save", system will calibrate size automatically.

#1 Move the calibration plate, press + - icon, regulate the red circle to coincide with calibration plate.

4.1.3 OPTICAL BLOCKER CALIBRATION



>Press icon , enter blocker calibration interface;

>Taking the calibration tool, insert into suction seat, rotate the arm of blocker, pressing down;

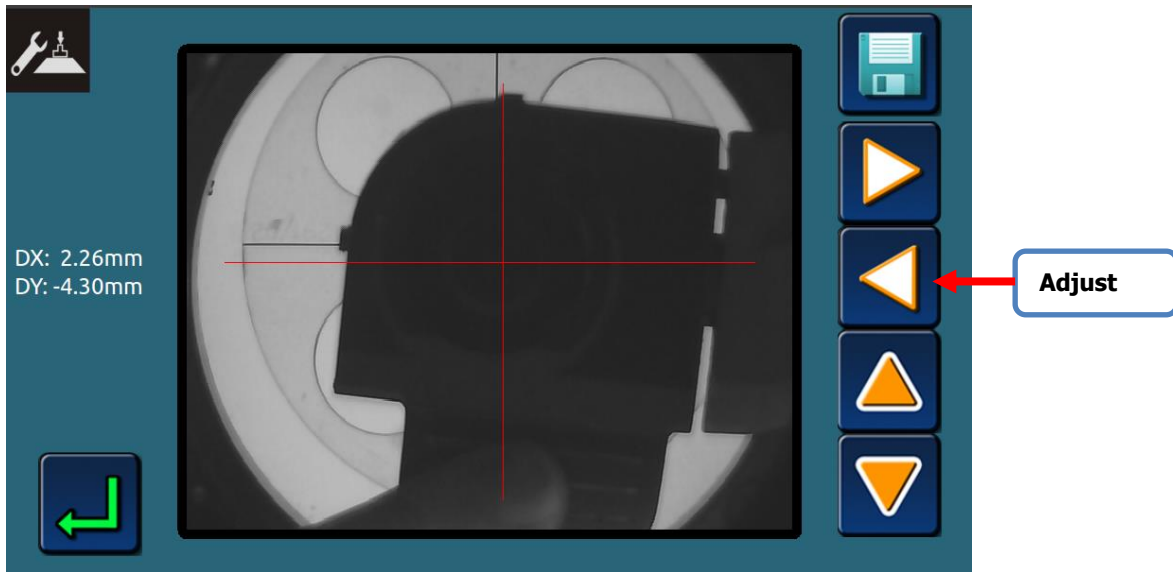

>Adjust horizontal and vertical red line to coincide with black line, press save icon;

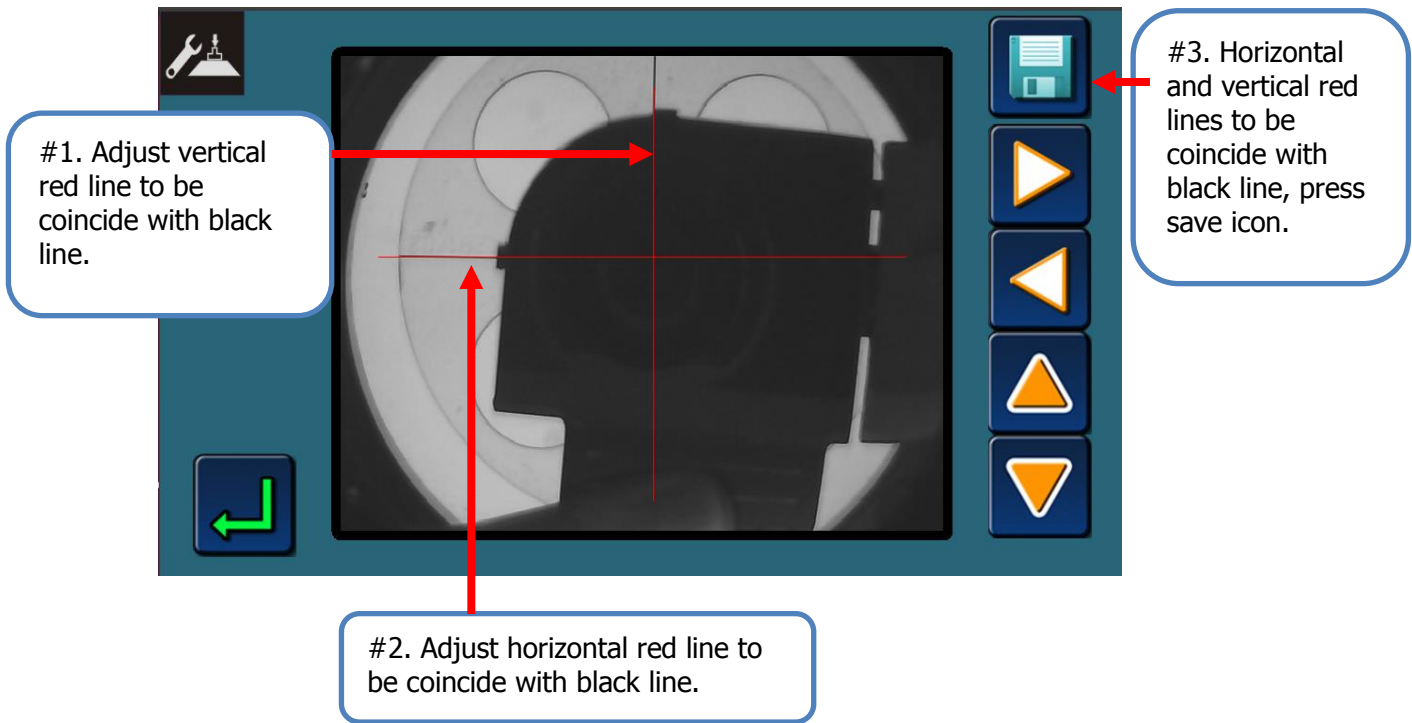

4.1.4 THE TEST MENU



>Press icon , enter the whole machine test menu.

Test



Packing



>> The performance test of the machine head lift motor and encoder;



>> Machine head horizontal moving motor, encoder performance test;



>> Performance test of lens rotary motor and encoder;



>> Scan probe component performance test;



>> Performance test of main motor and sprinkler system;



>> Performance test of clamp/loose system;



>> Machine test;



>> Performance test of grooving and safe chamfering function (**only apply to edger with grooving and safe chamfering function**) ;



Packing

>> Lock the carriage head, pack the whole machine for transportation.

4.1.5 SETTING MENU



>Press icon enter machine setting menu.

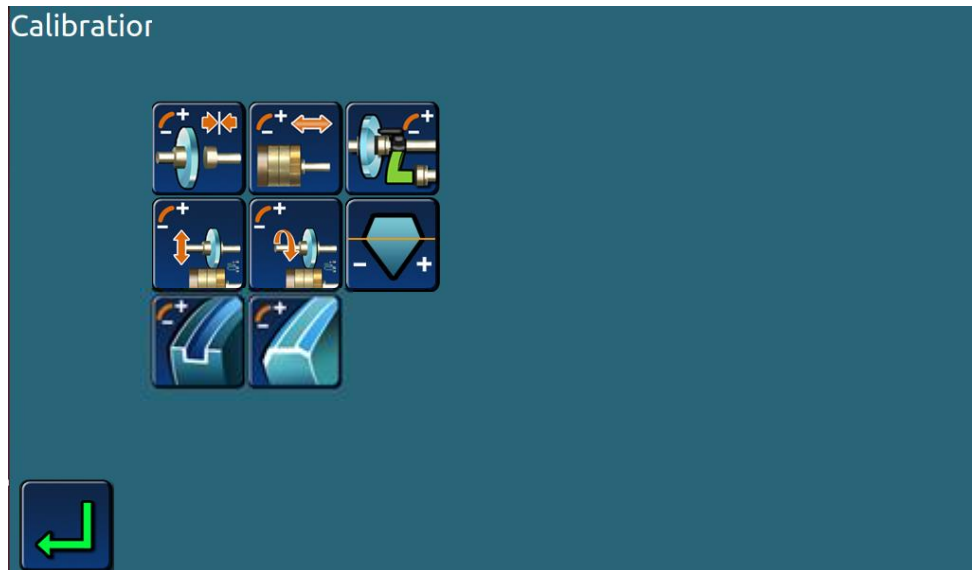

>> Clamp pressure correction;



>> Grinding wheel position correction;



>> Scanning probe correction;



>> Processing size setting;



>> Processing winding number setting;



>> Base axis setting.



>> Grooving setting (**only apply to edger with grooving and safe chamfering function**);



>> Safe chamfering setting (**only apply to edger with grooving and safe chamfering function**).

Note:

The parameter setting needs to be completed under the guidance of the professional after-sales service staff. Users should not enter the parameter setting menu by themselves.

Otherwise, improper operation may affect the performance of machine processing.

4.1.6 INITIAL PARAMETER SETTING



>Press icon enter initial parameter setting menu.



>Press icon after setting, saving initial parameter setting.

4.1.7 PROCESSING STATISTICS TABLE



>Press icon to view the processing statistics.

Statistics

	Rough	Bevel Finish	Rimles: Finish	Bevel Polish	Bevel Polish
CR39	0	0	0	0	0
HI	0	0	0	0	0
PC	0	0	0	0	0
Trivex	0	0	0	0	0
GL	0	0	0		
Total	0	0	0	0	0

Delete

5. DAILY MAINTENANCE OF MACHINERY

5.1 MAINTENANCE INSTRUCTIONS

To ensure that your edger is at its best, you must perform several maintenance operations to achieve the desired results within a range.

- > Clean touch screen
- > Maintenance of edger
 - >> Use water spray bottle to clean the edger
 - >> Regular replacement of movable lens block (every 100 lenses)
 - >> Regularly check the lens scanning probe, and change the probe once the wear or damage is found (or replacement per 3000 lenses)
 - >> Clean the baffle board and replace when necessary.
 - >> If the machine uses circulating water, replace the water in the tank regularly.
 - >> Wash the filter and water tank regularly.
 - >> Check the situation of each piece of grinding wheel. Please replace them under the technical person instruction when necessary.

5.2 MAINTENANCE OF TOUCH SCREEN PARTS

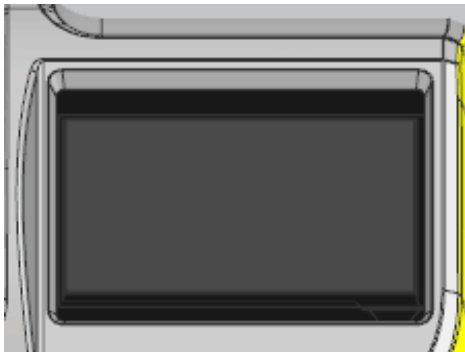

#1 Turn off the power switch if the machine is on;

#2 Gently wipe the touch screen with soft, dry linen.

Warning:

Disable such products as water or chemical reagents. If the stain is difficult to clean For dry cloth, it can be treated with alcohol. Damage caused by improper maintenance the touch screen, not within the warranty scope.

5.3 REPLACE REMOVABLE CLAMPS

Note: the lens holder is serrated and the lens probe is sharp. When touching the head and probe, make sure your hands are protected.

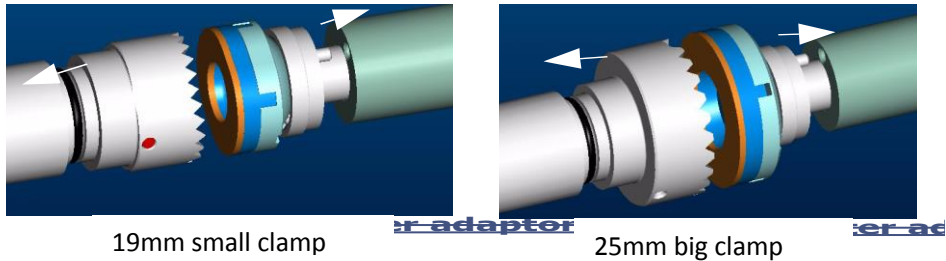

5.3.1 REPLACE THE RIGHT CLAMP RUBBER PAD

Replace the rubber pad procedure as below:

#1 Gently remove the right clamp from the clamp shaft;

#2 Remove the old rubber pad from the clamp-on and replace it with a new one;

#3 Put the right chuck back on the clamp axis.

As below pictures:

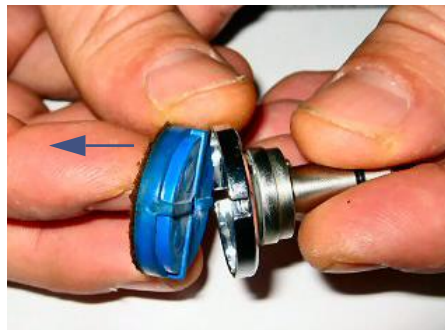
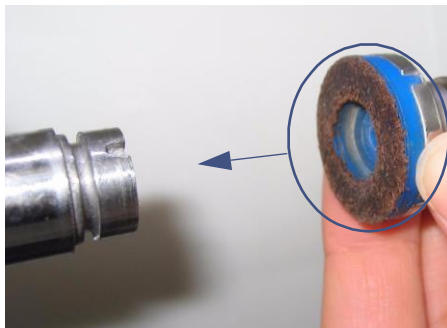

5.4 REPLACE LENS FEELER

> Check the lens scanner regularly, change the it once the wear or damage is found (Or replace every 3,000 lenses) .



Dismountable lens feeler



Remove the screws and replace the lens feeler

>After the lens feeler is replaced, the lens feeler position needs to be recalibrated.

The calibration probe procedure is as follows:



5.5 CLEAN/REPLACE WATER-PROOF COVER

> Before starting any operation, you must ensure that the machine switch is Off: the On/Off switch is in the Off position and the main power is disconnected.

The replacement procedure is as follows:

#1

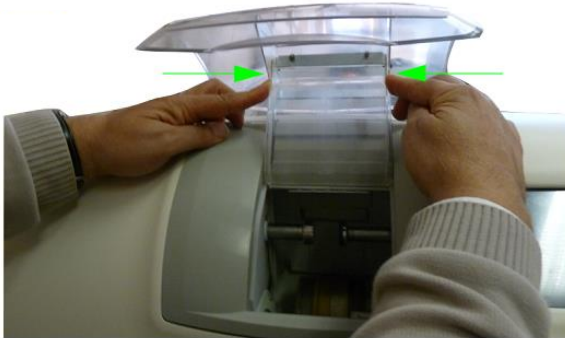

#2



NOTE:

> Regular cleaning of the cover plate can clearly see the grinding edge chamber and the processing process;

> The use of circulating water will affect the cleaning level of the water retaining board.

5.6 CLEAN THE FILTER AND WATER TANK

- > Before starting any operation, you must ensure that the machine switch is Off: the On/Off switch is in the Off position and the main power is disconnected.
- > Regular cleaning can ignore the number of lenses to be processed, but the manufacturer's recommendation is to clean about 100 pieces of lens (glass and plastic) per process.
- > Gloves and eye masks must be wear-resistant. It's better to wear overalls.

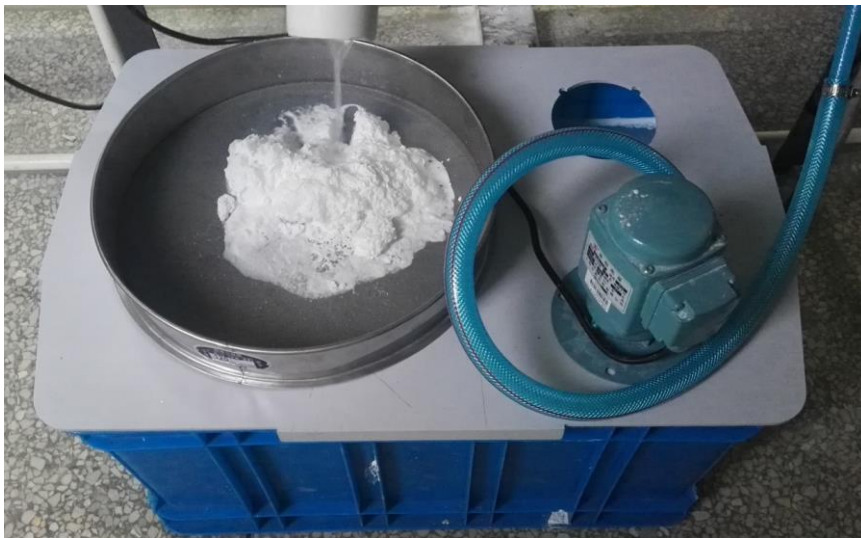

Please clean the water tank and filter regularly!

6. TECHNICAL SPECIFICATIONS

6.1 FEATURES

- > Automatic initialization
- > Three - dimensional probe front & rear surface camber
- > wheel configuration:
 - >> Glass grinding wheel
 - >> Resin rough wheel
 - >> Bevel/flat edge grinding wheel
 - >> Bevel/flat edge polishing wheel
- > Automatic clip, three selections of clip pressure, adapt to different material lens processing
- > Connect with water pump using circulating water and connect with solenoid valve when running water
- > Grinding diameter
 - >> ≤ 80 mm
 - >> Flat (No secured bevel) ≥ 19.00 mm
 - >> Bevel (No secured bevel) ≥ 19.00 mm
- > Automatic cleaning of lens fixing system and grinding room
- > Lens processing statistics

6.2 TECHNICAL PARAMETERS

- > The design standard is for indoor use
- > Dimension specification
 - >> Length: 705mm
 - >> Width: 465mm
 - >> Height: 442mm
- > Weight: 75kg
- > Input Voltage: 220V-230V/50Hz, 110V-115V/60Hz
- > Machine power: 1500W
- > Noise: 72db
- > Operating Temperature: 5°C~40°C
- > relative humidity: 10% - 80%
- > Pump working voltage: 220V-230V /50Hz, 110V-115V /60 Hz
- > Pump rated power: <=150W
- > FUSE:
 - 220V-230V /50Hz==15A
 - 110V-115V /60Hz==25A

7. ATTACHMENT LIST (PACKING PARTS)

NO.	PART NAME	QUANTITY
1	Block pliers	1
2	Butterfly head correction tool	1
3	Round calibration plate	1
4	Scan probe	3
5	25mm clamp	1
6	19mm clamp	1
7	25mm clamp rubber mat	2
8	19mmclamp rubber mat	2
9	Large block	5
10	Middle block	5
11	Sticker	1
12	Power line	1
13	Fuse (220V-15A or 110V-25A)	5
14	Certificate of conformity	1
15	Warranty card	1
16	Operation menu	1
17	Drier	2
18	Allen wrench (5*8)	1
19	Drain piper	1